

# Altima MAX™

Standard Elongated Two Piece Toilet 4045 130



# Altima MAX™

Standard Elongated Two Piece Toilet 4045 130



## Features

- 1.28 gpf Gravity flush
- Standard elongated bowl
- 12" Rough-in
- Left-hand color matched trip lever
- 3" flapper
- Fully glazed trapway
- Sanitary bar on bowl for easy cleaning
- Toilet seat not included
- Limited Lifetime Warranty



## Model

4045 Combination:

4385 Altima MAX Standard Elongated bowl

4140 Altima MAX 12" Rough-In tank

Shipping weight: 90 lbs (40 kg)

Optional tanks:

Right hand, 12" Rough-in (Model 4142)

Left hand, 10" Rough-in (Model 4144)

Left hand 14" Rough-in (Model 4145)

## Codes & Standards

Meets or exceeds the following:

- ASME A112.19.2
- CSA B45.1
- ICC A117.1-2017
- IAPMO/cUPC



## Specifications

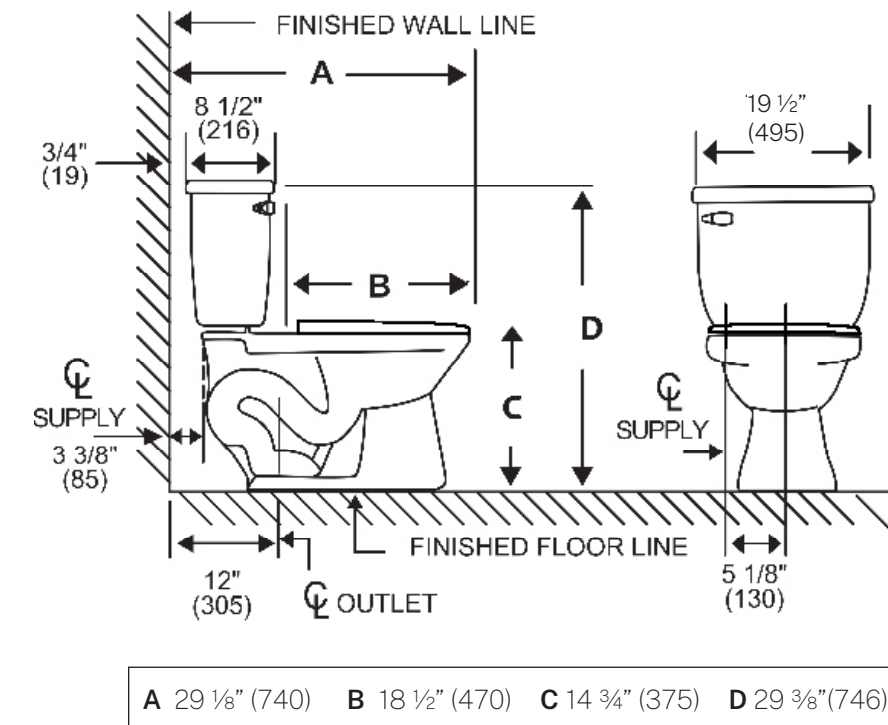

Material	Ceramic
Rough-In	12" (305mm)
Water Usage	1.28 gpf
Water Pressure Range	20/50/80 PSI
Flush System	3" Single Flush
Water Surface Area	≥ 125 * 100 mm

Trap Seal	≥ 51 mm
Trap Diameter	≥ 1 7/8"
Shipping Weight	90 lbs (40 kg)
Warranty	Ceramic: Lifetime Tank fittings: 1 year

## Colors

☐ White (130)

Dimensions may vary (+) or (-) 1/4". Dimensions shown in parentheses are in millimeters: 25.4 mm = 1 inch. Note: Fixture dimensions are nominal and conform with dimension and performance requirements of ASME A112.19.2-2008/CSA B45.1-08 standards. PSI rating: 20 minimum to 80 maximum per ASME A112.19.2-2008/CSA B45.1-08 standards. Dimensions subject to change or cancellation without notice. Briggs is not responsible for the use of superceded or voided specification information.